



Operating instructions Vibratory bowl feeder

SRC-N 160-2

SRC-N 200-2

SRC-B 200-2

SRC-N 250-2

SRC-B 250-2

SRC-N 400-1

SRC-N 400-2

SRHL 400-1

SRHL 400-2

SRC-N 630-1

SRC-N 800-1

BA

Rhein-Nadel Automation GmbH

Contents

| | Page |
|----------|--|
| 1 | Technical data..... 3 |
| 2 | Safety instructions..... 4 |
| 3 | Construction and function of the vibratory bowl feeder..... 5 |
| 4 | Transport and mounting..... 7 |
| 5 | Starting/Adjustment..... 8 |
| 6 | Maintenance.....11 |
| 7 | Stockkeeping of spare parts and after-sales service.....11 |
| 8 | What to do, if....?.....11 |
| | Instructions for trouble-shooting |



Declaration of conformity
as defined by
Low voltage directive 2006/95/EC

Herewith we declare that the product complies with the following provisions:
Low voltage directive 2006/95/EC

applied harmonized standards: DIN EN 60204 T1

remarks:

We assume that our product is to be integrated in a fixed machine. The provisions of the EMC directive 2004/108/EC has to be considered by the user.

Rhein-Nadel-Automation

Managing Director
Jack Grevenstein





Notice

All vibratory bowl feeders listed in the table may only be operated in connection with a RNA control unit at a mains voltage of 230V/50Hz. Special voltages and frequencies see separate data sheet.

1 Technical data

| Vibratory bowl feeder type ¹⁾ | SRC-N 160-2 | SRC-N 200-2 | SRC-B 200 | SRC-N 250-2 | SRC-B 250 | SRC-N 400-1 |
|---|--------------|--------------|--------------|--------------|--------------|-----------------------|
| Dimensions \varnothing x height[mm] | 157 x 132,5 | 180 x 165 | 180 x 165 | 290 x 215 | 290 x 215 | 440 x 228 |
| Weight[kg] | 7 | 11 | 11 | 40 | 40 | 103 |
| Insulation type | IP54 | IP54 | IP54 | IP54 | IP54 | IP 54 |
| Connecting cable length[m] | 1,40 | 1,40 | 1,40 | 0,50 | 0,50 | 0,5 |
| Power consumption ²⁾ [VA] | 110 | 240 | 240 | 519 | 519 | 753 |
| Current consumption ²⁾ [A] | 0,55 | 1,20 | 1,20 | 2,60 | 2,60 | 3,75 |
| Magnet nominal voltage/frequency ²⁾ [V/Hz] | 200/50 | 200/50 | 200/50 | 200/50 | 200/50 | 200/50 |
| Number of magnets | 1 | 1 | 1 | 3 | 3 | 3 |
| Magnet type | WZAW 040 | WZUW 080 | WZUW 080 | WZAW 060 | WZAW 060 | YZAW 080 |
| Magnet colour | black | black | black | Black | black | red |
| Air gap [mm] | 0,3 - 0,5 | 0,4 - 0,5 | 0,4 - 0,5 | 1 - 1,2 | 1 - 1,2 | 2,3 - 2,8 |
| Vibration frequency[Hz/min-1] | 100/6000 | 100/6000 | 100/6000 | 100/6000 | 100/6000 | 50 / 3000 |
| Number of spring assemblies | 3 | 3 | 3 | 3 | 3 | 3 |
| Standard no. of springs Number per spring assembly | 3x4 | 3x4 | 3x4 | 1x4 2x3 | 3x6 | 3 x 6 1 Satz Keile |
| Spring dimensions Length (gauge for boreholes) x width[mm] | 87 (67) x 20 | 87 (67) x 20 | 87 (67) x 20 | 106 (86) x35 | 106(86) x 35 | 139 (116) x 40 |
| Spring size[mm] | 1 | 1 | 1,5 | 2 | 2 | 2 |
| Quality of the spring fastening screws | 8.8 | 8.8 | 8.8 | 8.8 | 8.8 | 8.8 |
| Tightening torque spring fastening screws | 25 Nm | 25 Nm | 25 Nm | 100 Nm | 100 Nm | 100 Nm |
| Max. weight of the oscillating units depending on the mass moment of inertia and required running speed | 2,5 kg | 3,5 kg | 3,5 kg | 13 kg | 13 kg | 35 kg |

¹⁾ The last figure of the type identification shows the Vibration frequency: 1=50Hz (black mains cable), 2=100 Hz (grey mains cable)

²⁾ For special voltages (voltage, frequency) see type plate at the magnet

| Vibratory bowl feeder type ¹⁾ | SRC-N 400-2 | SRHL 400-1 | SRHL 400-2 | SRC-N630-1 | SRC-N800-1 |
|---|---------------|----------------|----------------|----------------|------------------------|
| Dimensions \varnothing x height[mm] | 440 x 228 | 470 x 249 | 470 x 249 | 660 x 225 | 805 x 315 |
| Weight[kg] | 103 | 140 | 140 | 168 | 270 |
| Insulation type | IP54 | IP54 | IP54 | IP54 | IP54 |
| Connecting cable length[m] | 0,50 | 0,50 | 0,50 | 0,50 | 1,40 |
| Power consumption ²⁾ [VA] | 786 | 1140 | 1060 | 1000 | 1700 |
| Current consumption ²⁾ [A] | 4,05 | 5,70 | 5,30 | 5 | 8,50 |
| Magnet nominal voltage ²⁾ [V/Hz] | 200/50 | 200/50 | 200/50 | 200/50 | 200/50 |
| Number of magnets | 3 | 2 | 2 | 4 | 4 |
| Magnet type | WZAW 080 | YZUW 090 | WZUW 090 | YZAW 080 | YZUW 090 |
| Magnet colour | black | red | black | red | red |
| Air gap [mm] | 1 - 1,2 | 2 - 2,8 | 1 - 1,5 | 2,3 - 2,8 | 2 - 3 |
| Vibration frequency[Hz/min-1] | 100/6000 | 50/3000 | 100/6000 | 50/3000 | 50/3000 |
| Number of spring assemblies | 3 | 6 | 6 | 4 | 12 |
| Standard no. of springs Number per spring assembly | 2x10 1x9 | 4x4 2x3 | 5x6 1x5 | 4x8 | 12x12 |
| Spring dimensions Length (gauge for boreholes) x width[mm] | 106 (86) x 35 | 139 (116) x 40 | 139 (116) x 40 | 139 (116) x 40 | 180 (156) x 60 (30) |
| Spring size[mm] | 2 | 2 | 3 | 2 | 2 |
| Quality of the spring fastening screws | 8.8 | 10.9 | 10.9 | 12.9 | 12.9 |
| Tightening moment spring fastening screws | 100 Nm | 120 Nm | 120 Nm | 120 Nm | 145 Nm |
| Max. weight of the oscillating units depending on the mass moment of inertia and required running speed | 35 kg | 45 kg | 45 kg | 50 kg | 80 kg |

¹⁾ The last figure of the type identification shows the Vibration frequency: 1=50Hz (black mains cable), 2=100 Hz (grey mains cable)

²⁾ For special voltages (voltage, frequency) see type plate at the magnet

Pin assignment

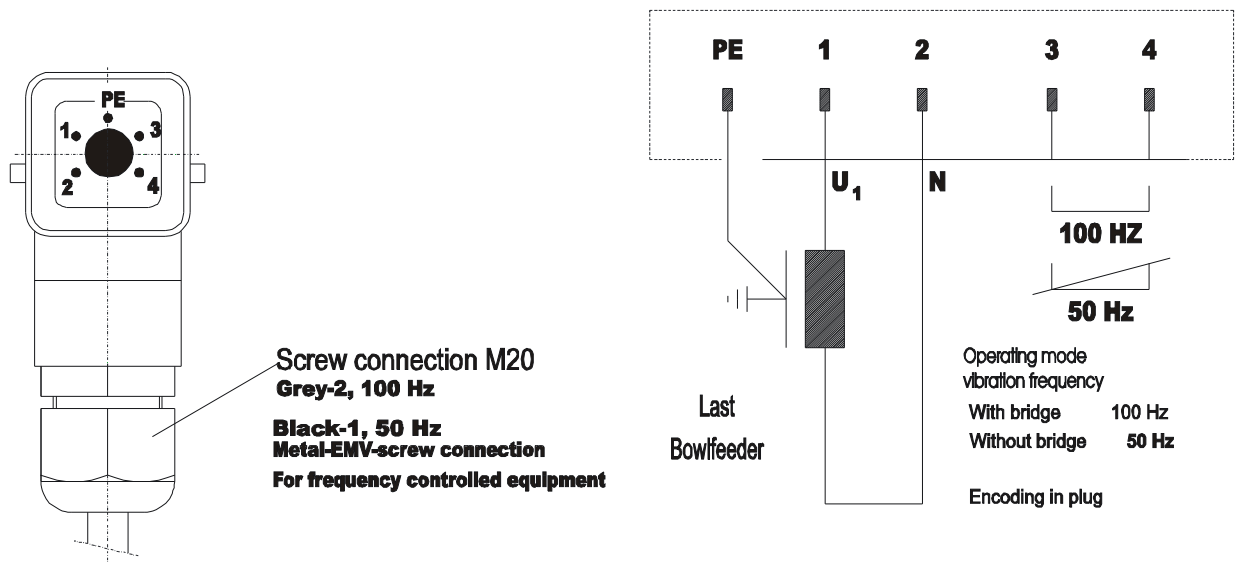

The bridge has to be installed in connection 3+4

2 Safety instructions

The conception and production of our vibratory bowl feeders has been carried out very careful, in order to guarantee a trouble-free and save operation. You too can make an important contribution to job safety. Therefore, please read this short operating instruction completely, before starting the machine. Always observe the safety instructions!

Make sure that all persons working with or at this machine carefully read and observe the following safety instructions!

This operating instruction is only valid for the types indicated on the front page.



Notice

This hand points to information that gives you useful tips for the operation of the vibratory bowl feeder.



Attention

This warning triangle marks the safety instructions. Non-observance of these warnings can result in serious or fatal injuries!

- Make sure that the protector ground of the electric power supply is in perfect condition!
- Operation of the vibratory bowl feeder without trim panel is strictly prohibited!

Proper use

The intended use of the vibratory bowl feeder is the actuation of sorting machines. These sorting machines are used for sorting and feeding correctly positioned mass-produced parts, as well as for the proportioned feeding of bulk material.

Using the machine for other purposes than the above mentioned, eg. as vibrating screen or in material testing, is considered not to be the intended use.

The intended use also includes the observance of the operating and servicing instructions. Please take the technical data of your vibratory bowl feeder from the table "technical data" (see chapt 2). Make sure that the connected load of the vibratory bowl feeder, control unit and power supply corresponds to each other.



Notice

The vibratory bowl feeder may only be operated in perfect condition!

The vibratory bowl feeder may only be operated in the configuration drive unit, control unit and bowl, as specified by the manufacturer.

The vibratory bowl feeder may not be operated in the explosive or wet area.

No additional loads may act upon the vibratory bowl feeder, apart from the bulk material, for which the special type is designed.



Attention

It is strictly prohibited to put any safety devices out of operation!

Demands on the user

- For all activities (operation, maintenance, repair, etc.) the details of the operating instructions must be observed.
- The operator has to refrain from any working method which would impair the safety of the vibratory bowl feeder.
- The operator has to take care that only authorized personnel works at the vibratory bowl feeder.
- The operator is obliged to inform the operator immediately about any changed conditions at the vibratory bowl feeder, which could endanger safety.



Attention

The vibratory bowl feeder may only be installed, put into operation and serviced by expert personnel. The binding regulation for the qualification of electricians and personnel instructed in electrical engineering is valid, as defined in IEC 364 and DIN VDE 0105 part 1.

Noise emission

The noise level at the place of operation depends on the total equipment and the material to be sorted. The determination of the noise level according to the EC-Regulations "Machinery" can therefore only be carried out at the place of operation.

If the noise level at the place of operation exceeds the limit permitted, noise protection hoods may be used, which we offer as accessory parts (see catalogue).

Standards and regulations

The device was built according to the following standards and regulations:

I Low voltage directive 2006/95/CE

I EMC directive 2004/108/CE

We assume that our product is to be integrated in a fixed machine. The provisions of the EMC directive 2004/108/CE has to be considered by the user.

I Applied harmonized Standards
EN 60204, T.1

3 Construction and function of the vibratory bowl feeder

Vibratory bowl feeders are used for the actuation of sorting machines. The actuation takes place by electromagnets. The following schematic diagram shows the function of a vibratory bowl feeder:

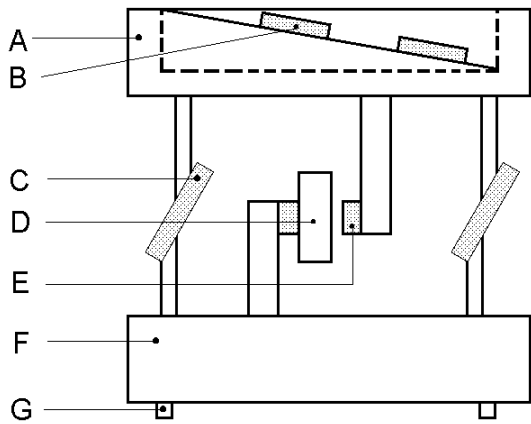

- A = Bowl
- B = Material to be conveyed
- C = Spring assembly
- D = Drive magnet
- E = Armature
- F = Counter-mass
- G = Vibration buffers

The drive magnet D is firmly connected with the counter-mass F. When current passes the drive magnet, it exerts power on armature E. The power is transmitted to bowl A, which is supported by the spring assembly C. The moving direction of the bowl is determined by the angle of the spring assemblies.

Owing to the vibrations the material to be conveyed is shortly lifted off the conveyor belt (track of the bowl) projecting it carries out little jumps (microprojection). The direction is in a right angle to the level of the spring assemblies.

The drive magnet achieves its maximum magnetic force twice during a period of the alternating current. Consequently the vibration frequency corresponds to the double mains frequency.

For heavy sorting installations a lower frequency of 50 Hz can be more advantageous.

The vibration frequency of your vibratory bowl feeder results from the last figure of the type designation:

- 1: 50 Hz - 3000 vibrations/min.
- 2: 100 Hz - 6000 vibrations/min.

A vibratory bowl feeder is a resonant system (spring-mass-system). The result is that the adjustment made at the plant will rarely meet your requirements. Chapter 4 shows how your vibratory bowl feeder is adapted to your requirements.

As accessory parts we are offering a spectrum of sorting bowls, which cover a wide range of application. For special applications individual problem solutions can be manufactured.

Controlling of the vibratory bowl feeder takes place by a low loss electronic control unit. The selection of the control unit depends on the power consumption of the vibratory bowl feeder. The following table shows the kind of control units that can be used at the individual vibratory bowl feeders:

| | ESG 2000 | ESK 2000 | ESG 1000 |
|--|----------|----------|----------|
| SRC-N 160 SRC-N 200 SRC-B 200 | ü | ü | ü |
| SRC-N 250 SRC-B 250 SRC-N 400 SRC-N 630 | ü | ü | ü |
| SRHL 400 SRC-N 800 | ü | ü | |

The control unit of the vibratory bowl feeder is mounted at the base plate. In case of vibratory bowl feeders without base plate it is separately packed. At its front plate the control unit is equipped with a connector with 7 poles, by which it is connected with the vibratory bowl feeder.

The pin assignment of the socket is shown in the table "technical data" on page 1-2 of this operating instruction.

At the type SRC-N 800 the control unit is separately delivered.



Notice

Detailed information on the complete range of control units may please be taken from the operating instructions for control units.

All control units have got two main operating elements:

- By the **mains switch** the vibratory bowl feeder is switched on or off.
 - By the **turning knob** the conveying capacity of the sorting unit is set.
-



Attention:

Since the electromagnetic-field may have an impact on persons arrying pacemakers it is recommended to keep a minimum distance of 25 cm.

4 Transport and mounting

Transport

For transport the vibratory bowl feeders are packed in stable wooden crates. After opening the cover, first loosen the screws at the bottom of the crate, by which the vibratory bowl feeder is secured.

For the transport of the vibratory bowl feeder a ring bolt (M16) is included in the delivery. At this ring bolt the vibratory bowl feeder can be transported by means of a suitable lifting equipment to the place where it is used.



Notice

When unpacking and transporting the vibratory bowl feeder please observe the instructions enclosed.

Depending on the construction type of the vibratory bowl feeder we distinguish the following cases:

- At vibratory bowl feeders with non-vibrating bottom the bottom plate must be lifted off for screwing down the ring bolt.
 - At vibratory bowl feeders with resonant (tightly screwed down) bottom plate the central plug must be removed for screwing down the ring bolt.
 - At sorting bowl types with single-hole mounting the bowl must be dismounted, in order to screw down the ring bolt.
 - At the vibratory bowl feeder SRC-N 800 the ring bolt can be screwed down after removing the central plastic cap or the cap nut (M16).
-



Notice

For operation the ring bolt must be removed.



Attention

The vibratory bowl feeder may not be lifted or transported at the sorting unit. Take care that the vibratory bowl feeder cannot dash against other objects during transport.

Make sure before transport that the lifting equipment used has got a sufficient load capacity for the individual vibratory bowl feeder. The weight of the vibratory bowl feeder may please be taken from the table "technical data" (see page 1-2).



Attention

During transport persons are not allowed to stay under the vibratory bowl feeder!

Mounting

At the place of operation the vibratory bowl feeder should be mounted on an especially developed RNA-frame. When using other frames take care that they have got a sufficiently high loading capacity! The frame used must be dimensioned that no vibrations of the vibratory bowl feeder get lost.

At mounting the vibratory bowl feeder we distinguish three cases:

- Vibratory bowl feeders with base plate can be fastened from the top.
- Vibratory bowl feeders without base plate are fastened at vibration buffers from below (part G in the general drawing on page 4).

The following table shows the bore hole data of the various types:

| Vibratory bowl feeder type | Hole circle Ø [mm] | Hole circle angle [°] | Vibration buffer thread |
|----------------------------|--------------------|-----------------------|-------------------------|
| SRC-N 160-2 | 120 | 3x120 | M 6 |
| SRC-N 200-2 | 130 | 3x120 | M 6 |
| SRC-B 200-2 | 130 | 3x120 | M 6 |
| SRC-N 250-2 | 220 | 3x120 | M 8 |
| SRC-B 250-2 | 220 | 3x120 | M 8 |
| SRC-N 400-1 | 350 | 3x120 | M 10 |
| SRC-N 400-2 | 350 | 3x120 | M 10 |
| SRHL 400-1 | 350 | 3x120 | M 10 |
| SRHL 400-2 | 350 | 3x120 | M 10 |
| SRC-N 630-1 | 560 | 3x120 | M 10 |

Table: bore hole data

The standard delivery of type SRC-N 800 includes a basic frame (see catalogue). This basic frame is screwed down with screws M10.

Make sure that the vibratory bowl feeder cannot come into contact with other devices during operation. Further details on the control unit (bore plan, etc.) are please taken from the operating instructions of the control unit separately delivered.

5 Starting

Preparations



Notice

Ensure that the frame (stand, base, frame etc.) is connected with the ground wire. (PE) If necessary, predection earthing on spot should be provided.

Check, whether

- the vibratory bowl feeder stands in an isolated position and does not come in contact with a solid body
- the sorting bowl is tightly screwed down
- the connecting cable of the vibratory bowl feeder is plugged in at the control unit.



Attention

The electric connection of the vibratory bowl feeder may only be made by trained personnel (electricians)! In case modifications are made at the electric connection, it is absolutely necessary to observe the operating instructions "control units".

- the available supply voltage (frequency, voltage, power delivery) corresponds to the connecting data of the control unit (see type plate at the control unit).

Plug in the mains cable of the control unit.

Switch on the control unit with the mains switch.



Notice

At vibratory bowl feeders which are delivered as a completely adjusted system, the optimal conveying capacity is already set in the factory. It is marked on the scale of the turning knob with a red arrow. In this case set the turning knob to the marking.

The optimal operative range of the vibratory bowl feeder is at a controller position of 80% at the control unit. In case of higher deviations ($\geq \pm 15\%$) a new adjustment must be made. This adjustment is described on the following page.

Adjustment

In the factory the vibratory bowl feeders are approximately adjusted to standard sorting bowls (without sorting element).

In order to guarantee an optimal sorting behaviour, the vibratory bowl feeder must be adjusted to the concrete operating conditions.

The adjustment is made by adding or removing leaf springs and washers.

First check, whether the right control unit (frequency, voltage, power supply, see table on chap 1) has been connected.

Carry out the following steps:

- Screw off the jacket sheet. Tighten all spring fastening screws and bowl fastening screws. Please take the tightening moments of the spring fastening screws from the technical data (see table on chap 1-2).
- Check, whether the magnets correspond to the specifications in the technical data.
- Measure the magnet-air gap. In case it differs from the specifications in the technical data, adjust it correctly.
- Fill the bowl with material to be conveyed. Switch on the vibratory bowl feeder and set the turning head to 90% conveying capacity
- Loosen the lower fastening screw at one of the spring assemblies (approx. 1/4-1/2 rotation).

While the spring fastening screw is loosened, you can see a change in the conveying speed.

The following graphic chart shows the resonance curve of a vibratory bowl feeder:

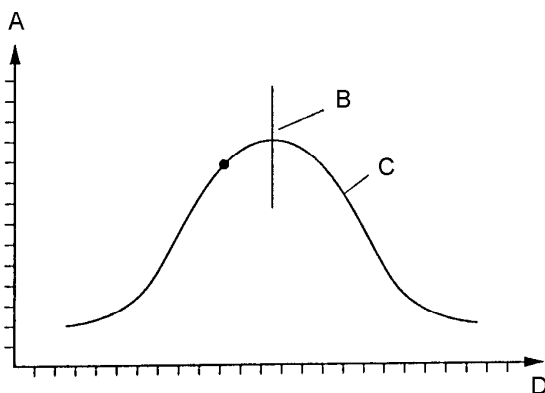

- A = Conveying speed**
- B = Resonance frequency of the system**
- C = Resonance curve (not true to scale)**
- D = Spring power (number of springs)**

**Notice**

The resonant frequency of the vibratory bowl feeder may not correspond to the mains frequency.

In case the conveying capacity decreases after loosening the spring fastening screw, proceed as described under point 5.1.

In case, however, the conveying capacity, increases, proceed as described under point 5.2.

**Notice**

The adjustment is, however, more easy with an electronic frequency converter, which you can buy from our range of accessory parts.

The vibratory bowl feeder should be adjusted that the required conveying capacity is achieved at a controller position of approx. 80% at the control unit.

5.1 The conveying speed decreases?

Mount additional springs. Start with one additional spring (with washer) at one spring assembly. In case the conveying speed still decreases, although an additional fastening screw is loosened, install one additional spring in each individual spring assembly (one after the other).

5.2 The conveying speed increases?

Remove the springs. First remove one spring (with washer) from a spring assembly. In case the conveying speed still increases, although an additional fastening screw is loosened, remove one spring from each individual spring assembly (one after the other).

**Notice**

As the adjustment is made while the jacket sheet is dismantled, a further spring must be installed after the optimal adjustment. Consequently the influence of the jacket sheet on the frequency is neutralized. At the type SRC-N 800 6 additional springs (one each in every second spring assembly) must be installed.

The aim of the adjustment is:

If the required conveying speed is achieved at a controller position of 80 %, the conveying speed must always decrease when the spring fastening screw is loosened.

**Notice**

Take care that the number of springs per spring assembly does not differ by more than 2-3 springs. Otherwise the conveying speed at the circumference of the bowl will become irregular.

The conveying speed is irregular?

In case the conveying speed is irregular at the circumference of the conveying bowl, you can balance the bowl by installing counter weights.

- Therefore fix a counter weight at the "fast" point.

In case it is impossible to install a counter weight, the following may also be done:

- Remove a spring from the spring assembly at the "slow" point.
- Install an additional spring in the spring assembly at the "fast" point.

6 Maintenance

The vibratory bowl feeders are generally maintenance-free. They should only be thoroughly cleaned when they are considerably dirty or after fluids have been spilled over them.

- For that first unplug the mains plug.
- Remove the jacket sheet.
- Clean the inside of the vibratory bowl feeder, especially the magnetic gap.
- After mounting the jacket sheet and plugging in the mains plug, the vibratory bowl feeder is ready for operation again.

7 Stockkeeping of spare parts and after-sales service

The range of the spare parts available may be taken from the separate spare parts list.

In order to guarantee a quick and faultless handling of the order, please state the following data at each individual order:

- Type of equipment (see type plate)
- Number of pieces needed
- Spare part name
- Spare part number

You will find a list of our service addresses on the back page of the cover

8 What happens, if...

Instructions for trouble-shooting



Attention

The control unit or the connecting terminal box may only be opened by an electrician. Before opening the a.m. devices, the mains plug must be unplugged!

| . Trouble | Possible cause | Remedy |
|--|---|--|
| Vibratory bowl feeder does not start at being switched on | <p>Mains plug of the control</p> <p>Connecting cable between vibratory bowl feeder and control unit not plugged in</p> <p><i>Only in connection with control unit ESK 2000</i> Sensor gives the faulty message of pile-up, owing to defect or maladjustment (green LED at the vibratory bowl feeder STOP</p> <p>Fuse in the control unit defect</p> <p>Mains switch off</p> | <p>Plug in the mains plug unit is not plugged in</p> <p>Plug in the 5-pole plug at the control unit</p> <p>Replace the sensor or readjust it</p> <p>Check whether the sensor is plugged in</p> <p>Replace the fuse</p> <p>Switch on the mains switch</p> |
| <p>The vibratory bowl feeder vibrates only slightly</p> <div style="text-align: center;"></div> | <p>Controller at the control</p> <p>Wrong vibration frequency</p> <p>Attention In case a vibratory bowl feeder for 6000 vibrations/min. is operated without bridge in a 7-pole plug, the control unit and the magnets are in danger!</p> | <p>Set the controller to 80 % unit is set to 0%</p> <p>Check, whether the code at the plug of the control unit is correct. (see type plate and technical data, chap 1)</p> |
| After a longer operating time the vibratory bowl feeder does not achieve the required capacity | <p>Screws at one or several spring assemblies have worked loose</p> <p>Springs are broken</p> <p>Magnetic gap misadjusted</p> <p>Fastening screws of the sorting bowl have worked loose</p> | <p>Tighten the screws (tightening torques see table "technical data" on chap 1)</p> <p>Replace broken springs</p> <p>Readjust magnetic gap (necessary gap width see table "technical data" on page 1-2)</p> <p>Tighten the screws</p> |
| Vibratory bowl feeder makes loud noise | <p>Fastening screws of the jacket sheet have worked loose</p> <p>Bottom of the bowl got jammed</p> <p>Foreign bodies in the magnetic gap (chips, material to be conveyed, dust)</p> <p><i>Only SRHL 400 and SRC-N 800:</i> Counter screw at the tie plate has worked loose</p> | <p>Tighten the screws</p> <p>Eliminate the jam</p> <p>Switch off the vibratory bowl feeder and remove the foreign bodies. Control the adjustment of the magnetic gap</p> <p>Retighten the screw</p> |
| Vibratory bowl feeder cannot be set to a constant conveying speed | The spring rate of the vibratory system has changed. The vibratory bowl feeder operates close at the resonance point | Readjust the vibratory bowl feeder. Springs must be removed. See chapter 5 - Adjustments |



D

Rhein-Nadel Automation GmbH

Reichsweg 19/23 Ľ D - 52068 Aachen
Tel (+49) 0241/5109-159 Ľ Fax (+49) 0241/5109-219
Internet www.rna.de Ľ Email vertrieb@rna.de

Rhein-Nadel Automation GmbH

Zweigbetrieb Lüdenscheid
Nottebohmstraße 57 Ľ D - 58511 Lüdenscheid
Tel (+49) 02351/41744 Ľ Fax (+49) 02351/45582
Email werk.luedenscheid@rna.de

Rhein-Nadel Automation GmbH

Zweigbetrieb Ergolding
Ahornstraße 122 Ľ D - 84030 Ergolding
Tel (+49) 0871/72812 Ľ Fax (+49) 0871/77131
Email werk.ergolding@rna.de

CH

HSH Handling Systems AG

Wangenstr. 96 Ľ CH - 3360 Herzogenbuchsee
Tel (+41) 062/95610-00 Ľ Fax (+41) 062/95610-10
Internet www.rna.de Ľ Email info@handling-systems.ch

GB

RNA AUTOMATION LTD

Hayward Industrial Park
Tameside Drive, Castle Bromwich
GB - Birmingham, B 35 7 AG
Tel (+44) 0121/749-2566 Ľ Fax (+44) 0121/749-6217
Internet www.rna-uk.com Ľ Email rna@rna-uk.com

E

Vibrant S.A.

Pol. Ind. Famades C/Energia Parc 27
E - 08940 Cornellà Llobregat (Barcelona)
Tel (+34) 093/377-7300 Ľ Fax (+34) 093/377-6752
Internet www.vibrant-rna.com Ľ Email info@vibrant-rna.com